

Small-Sized 1.8V Operating Voltage Fundamental Quartz Crystal Oscillator IC

■GENERAL DESCRIPTION

The NJU6214 series is a C-MOS quartz crystal oscillator IC realized excellent frequency stability for fundamental (up to 60MHz) oscillation, and consists of an oscillation amplifier, 4-stage divider, 3-state output buffer and a built-in LDO.

The operating voltage is from 1.62V to 3.63V, and the LDO holds down the characteristic change of the oscillation amplifier for operating voltage variation, and has been stabilized oscillation frequency.

The 4-stage divider generates only one frequency selected of f_0 , $f_0/2$, $f_0/4$, $f_0/8$ and $f_0/16$ internal circuits is output.

The 3-state output buffer is C-MOS compatible of high fan-out.

The oscillation stopping current is very low stand-by mode below 1uA, therefore, it is suitable for the portable items of the communication equipment and the like.

The pad arranges "L" location to be easy to put on 2016 size oscillator by wire bonding.

■FEATURES

- Frequency Stability $\pm 1\text{ppm}@V_{DD}\pm 10\%$
- Operating Voltage 1.62 to 3.63V
- Maximum Oscillation Frequency Up to 60MHz
- Low Operating Current 5mA typ. @60MHz/3.3V/15pF
- 4-Stage Divider Maximum Divider $f_0/16$
- Built-in LDO
- Oscillation Stop and Output Stand-by Function
- 3-State Output Buffer
- Variable Pull-up Resistance on-Die
- Oscillation Capacitors C_g and C_d on-Die
- Package Outline Die/Wafer
- C-MOS Technology

■LINE-UP TABLE

Type No.	F_{OUT}	Internal Connect			Cg/Cd	
		Short	Open	N		
NJU6214	A	f_0	A	B	-	9.3/10.7pF
	B	$f_0/2$	B	A	2	9.3/10.7pF
	C	$f_0/4$	B	A	4	9.3/10.7pF
	D	$f_0/8$	B	A	8	9.3/10.7pF
	*E	$f_0/16$	B	A	16	9.3/10.7pF

* Under Development

■EXAMPLE OF PART NUMBER

- 1) NJU6214AW-L
 $F_{OUT}=f_0$, Wafer Thickness=140um
- 2) NJU6214CC-V
 $F_{OUT}=f_0/4$, Die Thickness=130um

■PACKAGE OUTLINE



NJU6214XC-X

■PAD LOCATION

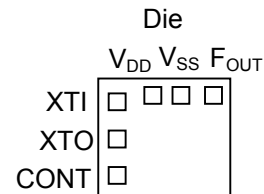

■COORDINATES

No	Pad Name	X	Y
1	CONT	-189	231
2	XT1	-189	77
3	XTO	-189	-77
4	V _{SS}	-189	-231
5	F _{OUT}	215	-231
6	V _{DD}	222	231

Starting Point: Die Center Unit[um]

Die Size: 0.64x0.60mm

Die Thickness (C-V): 130±10um

Die Thickness (C-L): 140±10um

Wafer Thickness (W-V): 130±10um

Wafer Thickness (W-L): 140±10um

Pad size: 70x70um

Die Substrate: V_{SS} level

■BLOCK DIAGRAM

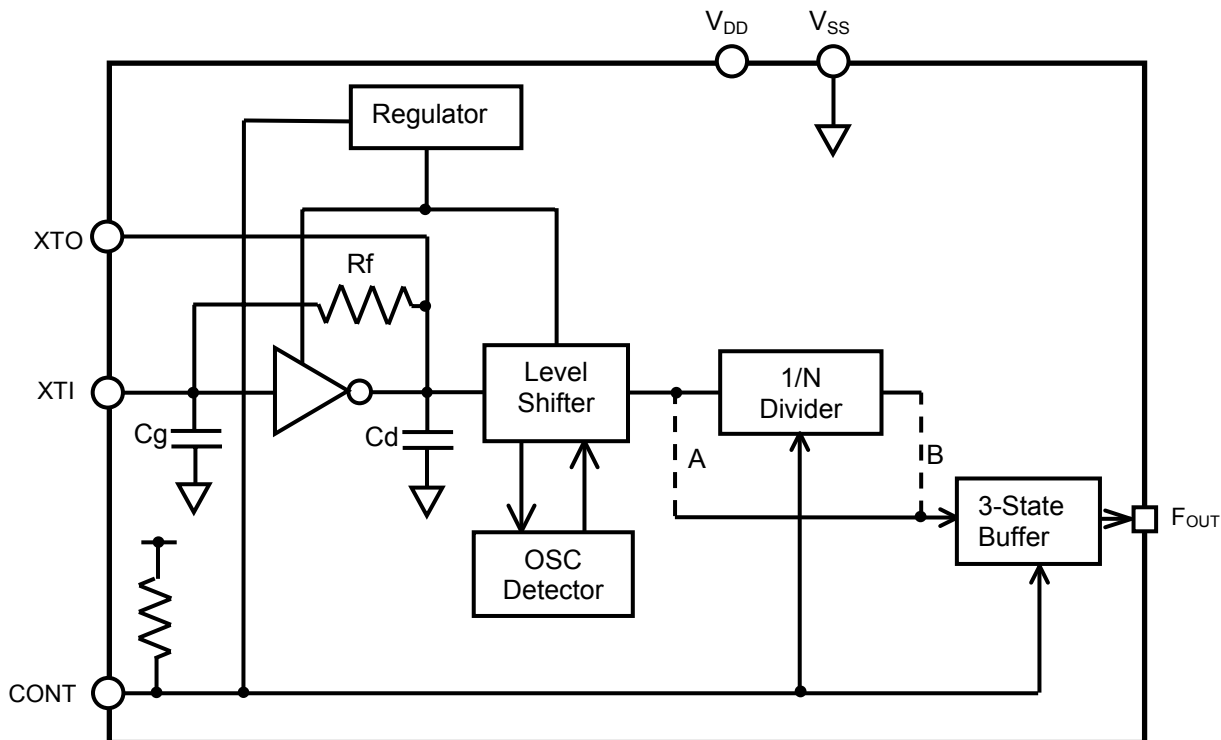

■TERMINAL DESCRIPTION

SYMBOL	FUNCTION
CONT	Oscillation and 3-state Output Buffer Control
	CONT F _{OUT}
	H or OPEN Output either one frequency selected of f ₀ , f ₀ /2, f ₀ /4, f ₀ /8 and f ₀ /16 (Note1)
	L Oscillation Stop and High impedance Output
XTI XTO	Quartz Crystal Connecting Terminals
V _{SS}	V _{SS} =0V : GND
F _{OUT}	Frequency Output
V _{DD}	V _{DD} =1.62 to 3.63V

Note1) Refer to the line-up table.

■ABSOLUTE MAXIMUM RATINGS

(V_{SS}=0V, Ta=25°C)

PARAMETER	SYMBOL	RATING	UNIT
Supply Voltage	V _{DD}	-0.5 to +7.0	V
Input Voltage	V _{IN}	-0.5 to V _{DD} +0.5	V
Output Voltage	V _O	-0.5 to V _{DD} +0.5	V
Input Current	I _{IN}	±10	mA
Output Current	I _O	±25	mA
Operating Temperature Range	T _{opr}	-40 to +85	°C
Storage Temperature Range	T _{stg}	-55 to +125	°C

Note2) If the supply voltage(V_{DD}) is less than 7.0V, the input voltage must not over the V_{DD} level though 7.0V is limit specified.

Note3) Decoupling capacitor should be connected between V_{DD} and V_{SS} due to the stabilized operation for the circuit.

■ ELECTRICAL CHARACTERISTICS

(Ta=25°C)

PARAMETER	SYMBOL	CONDITIONS	MIN	TYP	MAX	UNIT
Operating Voltage	V _{DD}	fosc=60MHz	1.62		3.63	V
Output Frequency Stability	df/f	V _{DD} ±10%		±1		ppm

(V_{DD}=1.8V, Ta=+25°C)

PARAMETER	SYMBOL	CONDITIONS	MIN	TYP	MAX	UNIT
Operating Current	I _{DD}	A version, f ₀ =60MHz, C _L =15pF		3.0	4.0	mA
		B version, f ₀ /2=30MHz, C _L =15pF		1.8	2.6	
		C version, f ₀ /4=15MHz, C _L =15pF		1.3	2.0	
		D version, f ₀ /8=7.5MHz, C _L =15pF		1.0	2.0	
		*E version, f ₀ /16=3.75MHz, C _L =15pF		0.9	2.0	
Oscillation Stopping Current	I _{STB}	CONT=V _{SS} , No load			1	uA
Input Voltage	V _{IH}		1.26		1.8	V
	V _{IL}		0		0.54	V
Output Voltage	V _{OH}	I _{OH} =2mA	1.62			V
	V _{OL}	I _{OL} =2mA			0.18	V
Input Current	I _{IN}	CONT=0.8V _{DD}		1.9	2.7	uA
		CONT=0.2V _{DD}		0.1	0.25	uA
3-state Off Leakage Current	I _{OZ}	CONT=V _{SS} , F _{OUT} = V _{DD} or V _{SS}			±0.1	uA
Feedback Resistance	R _f			270		kΩ
Internal Capacitor	C _g	fosc=60MHz		9.3		pF
Internal Capacitor	C _d	fosc=60MHz		10.7		pF
Oscillation Frequency	fosc	Recommendation Note4)			60	MHz
Output Signal Symmetry	SYM	C _L =15pF, @V _{DD} /2	45	50	55	%
Output Signal Rise Time	t _r	C _L =15pF, 0.1V _{DD} to 0.9V _{DD}		3.2	5.0	ns
Output Signal Fall Time	t _f	C _L =15pF, 0.9V _{DD} to 0.1V _{DD}		3.2	5.0	ns
Output Disable time	T _{POZ}	C _L =15pF, R _L =1kΩ			100	ns
Output Enable Time	T _{PZO}	C _L =15pF			1	ms

Note4) The oscillation frequency range has used NJRC's standard crystal for measurement. However it is not guaranteed. (Refer to EXAMPLE OF CRYSTAL PARAMETERS FOR MEASUREMENT CIRCUITS)

* Under Development.

($V_{DD}=2.5V, T_a=+25^{\circ}C$)

PARAMETER	SYMBOL	CONDITIONS	MIN	TYP	MAX	UNIT
Operating Current	I_{DD}	A version, $f_0=60MHz, C_L=15pF$		3.7	5.0	mA
		B version, $f_0/2=30MHz, C_L=15pF$		2.4	3.3	
		C version, $f_0/4=15MHz, C_L=15pF$		1.6	2.4	
		D version, $f_0/8=7.5MHz, C_L=15pF$		1.2	2.0	
		*E version, $f_0/16=3.75MHz, C_L=15pF$		1.0	2.0	
Oscillation Stopping Current	I_{STB}	CONT= V_{SS} , No load			1	μA
Input Voltage	V_{IH}		1.75		2.5	V
	V_{IL}		0		0.75	V
Output Voltage	V_{OH}	$I_{OH}=4mA$	2.25			V
	V_{OL}	$I_{OL}=4mA$			0.25	V
Input Current	I_{IN}	CONT= $0.8V_{DD}$		4.2	9.0	μA
		CONT= $0.2V_{DD}$		0.3	0.6	μA
3-state Off Leakage Current	I_{OZ}	CONT= V_{SS} , $F_{OUT}=V_{DD}$ or V_{SS}			± 0.1	μA
Feedback Resistance	R_f			270		k Ω
Internal Capacitor	C_g	$f_{osc}=60MHz$		9.3		pF
Internal Capacitor	C_d	$f_{osc}=60MHz$		10.7		pF
Oscillation Frequency	f_{osc}	Recommendation Note4)			60	MHz
Output Signal Symmetry	SYM	$C_L=15pF, @V_{DD}/2$	45	50	55	%
Output Signal Rise Time	t_r	$C_L=15pF, 0.1V_{DD}$ to $0.9V_{DD}$		2.2	3.7	ns
Output Signal Fall Time	t_f	$C_L=15pF, 0.9V_{DD}$ to $0.1V_{DD}$		2.2	3.7	ns
Output Disable time	T_{POZ}	$C_L=15pF, R_L=1k\Omega$			100	ns
Output Enable Time	T_{PZO}	$C_L=15pF$			1	ms

Note4) The oscillation frequency range has used NJRC's standard crystal for measurement. However it is not guaranteed. (Refer to EXAMPLE OF CRYSTAL PARAMETERS FOR MEASUREMENT CIRCUITS)

* Under Development.

($V_{DD}=3.3V, T_a=+25^{\circ}C$)

PARAMETER	SYMBOL	CONDITIONS	MIN	TYP	MAX	UNIT
Operating Current	I_{DD}	A version, $f_0=60MHz, C_L=15pF$		5.0	7.0	mA
		B version, $f_0/2=30MHz, C_L=15pF$		3.2	4.4	
		C version, $f_0/4=15MHz, C_L=15pF$		2.2	3.0	
		D version, $f_0/8=7.5MHz, C_L=15pF$		1.7	2.5	
		*E version, $f_0/16=3.75MHz, C_L=15pF$		1.5	2.3	
Oscillation Stopping Current	I_{STB}	CONT= V_{SS} , No load			10	μA
Input Voltage	V_{IH}		2.31		3.3	V
	V_{IL}		0		0.99	V
Output Voltage	V_{OH}	$I_{OH}=6mA$	2.97			V
	V_{OL}	$I_{OL}=6mA$			0.33	V
Input Current	I_{IN}	CONT= $0.8V_{DD}$		7.8	16.0	μA
		CONT= $0.2V_{DD}$		0.6	1.2	μA
3-state Off Leakage Current	I_{OZ}	CONT= V_{SS} , $F_{OUT}=V_{DD}$ or V_{SS}			± 0.1	μA
Feedback Resistance	R_f			270		k Ω
Internal Capacitor	C_g	fosc=60MHz		9.3		pF
Internal Capacitor	C_d	fosc=60MHz		10.7		pF
Oscillation Frequency	fosc	Recommendation Note4)			60	MHz
Output Signal Symmetry	SYM	$C_L=15pF, @V_{DD}/2$	45	50	55	%
Output Signal Rise Time	tr	$C_L=15pF, 0.1V_{DD}$ to $0.9V_{DD}$		1.8	3.0	ns
Output Signal Fall Time	tf	$C_L=15pF, 0.9V_{DD}$ to $0.1V_{DD}$		1.8	3.0	ns
Output Disable time	T_{POZ}	$C_L=15pF, R_L=1k\Omega$			100	ns
Output Enable Time	T_{PZO}	$C_L=15pF$			1	ms

Note4) The oscillation frequency range has used NJRC's standard crystal for measurement. However it is not guaranteed. (Refer to EXAMPLE OF CRYSTAL PARAMETERS FOR MEASUREMENT CIRCUITS)

* Under Development.

EXAMPLE OF CRYSTAL PARAMETERS FOR MEASUREMENT CIRCUITS

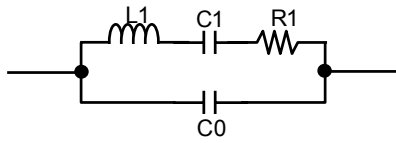

f[MHz]	R1[Ω]	L1[mH]	C1[fF]	C0[pF]
60	31.2	3.75	1.87	0.92

MEASUREMENT CIRCUITS

(1) Operating Current, Output Signal Symmetry, Output Signal Rise/Fall Time ($C_L=15\text{pF}$)

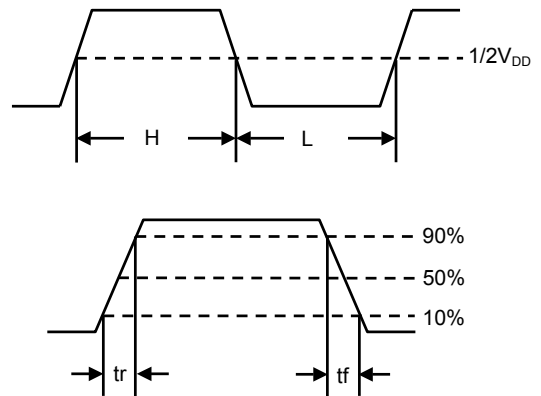
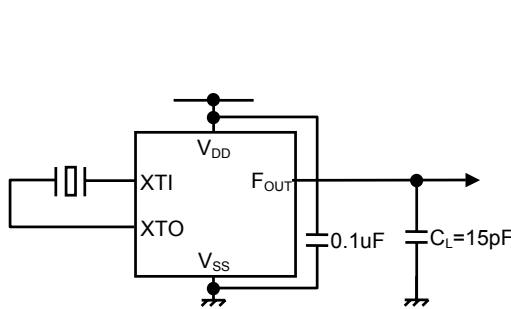

(2) Output Disable Time ($C_L=15\text{pF}, R_L=1\text{k}\Omega$)

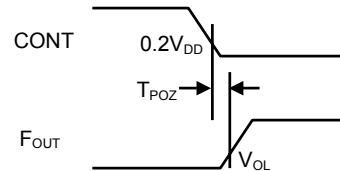
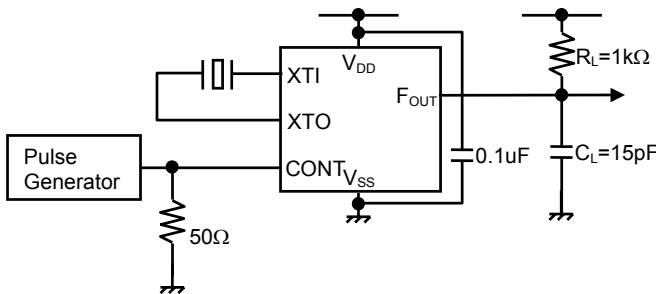

(3) Output Enable Time ($C_L=15\text{pF}$)

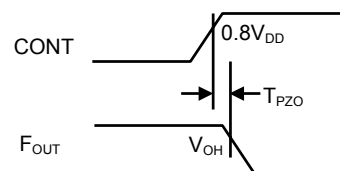
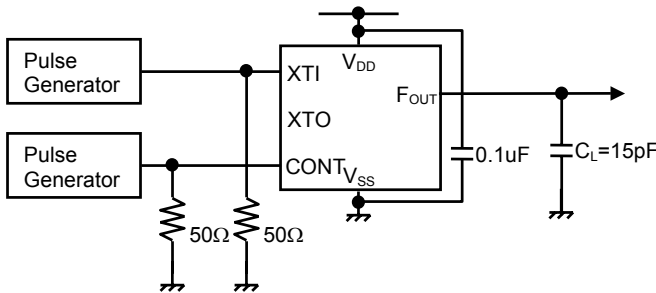

■ 2016 SIZE OSCILLATOR IMAGE DIAGRAM

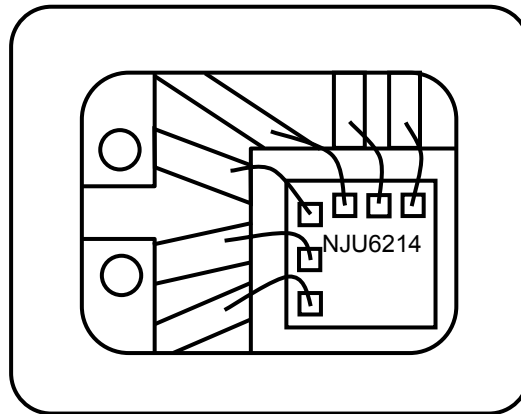

[CAUTION]

The specifications on this data book are only given for information, without any guarantee as regards either mistakes or omissions. The application circuits in this data book are described only to show representative usages of the product and not intended for the guarantee or permission of any right including the industrial rights.